

5- MASTER BATH #207

SCALE: 3/8"=1'-0"

1-CW., CLOSET #206

SCALE: 3/8"=1'-0"

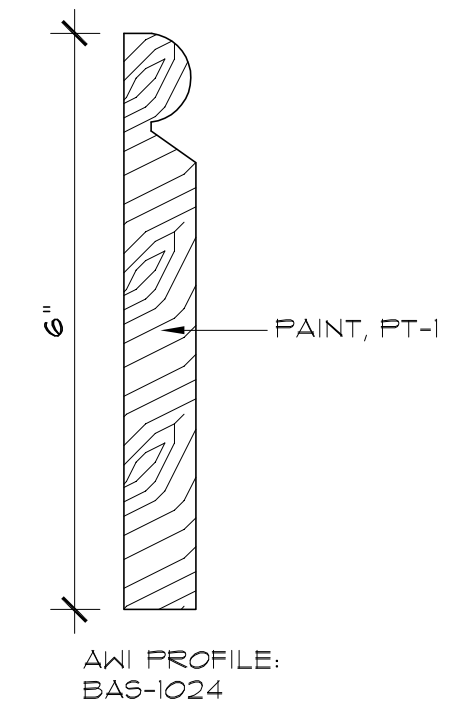
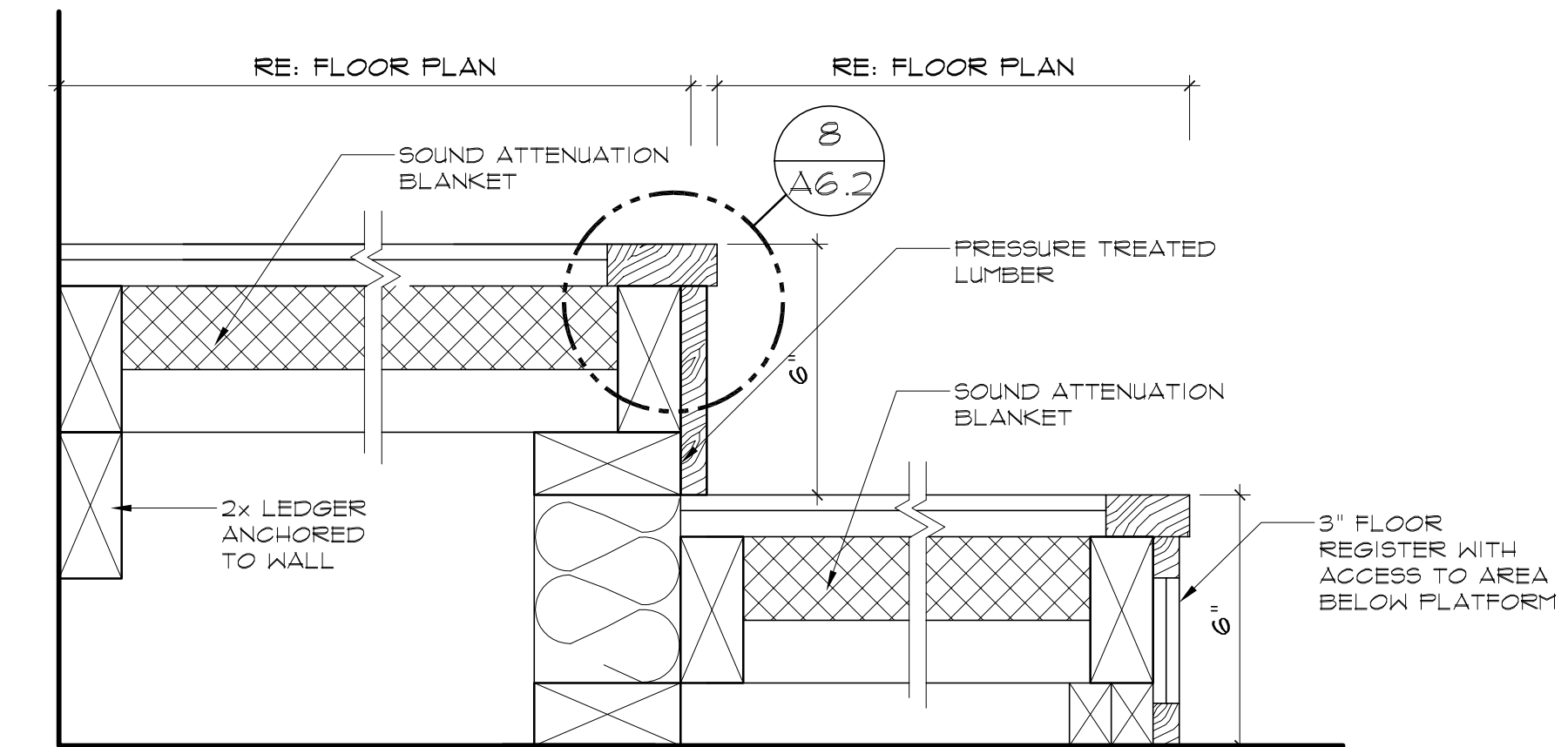
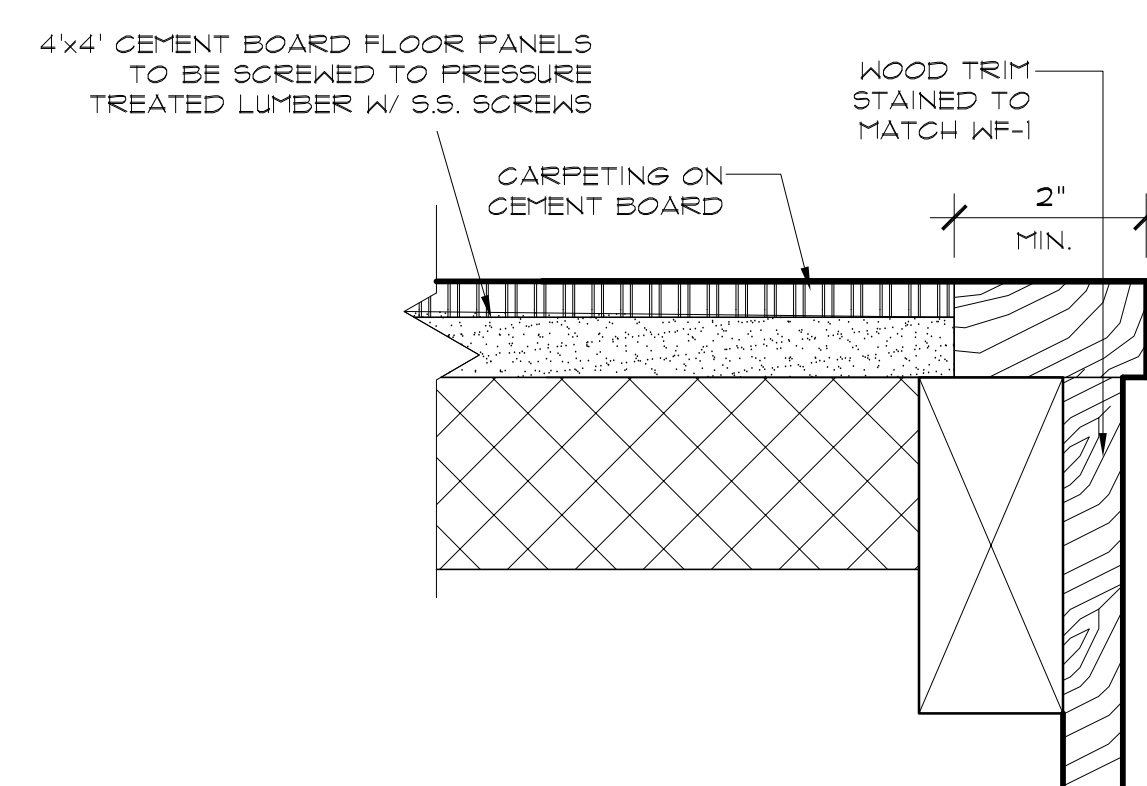
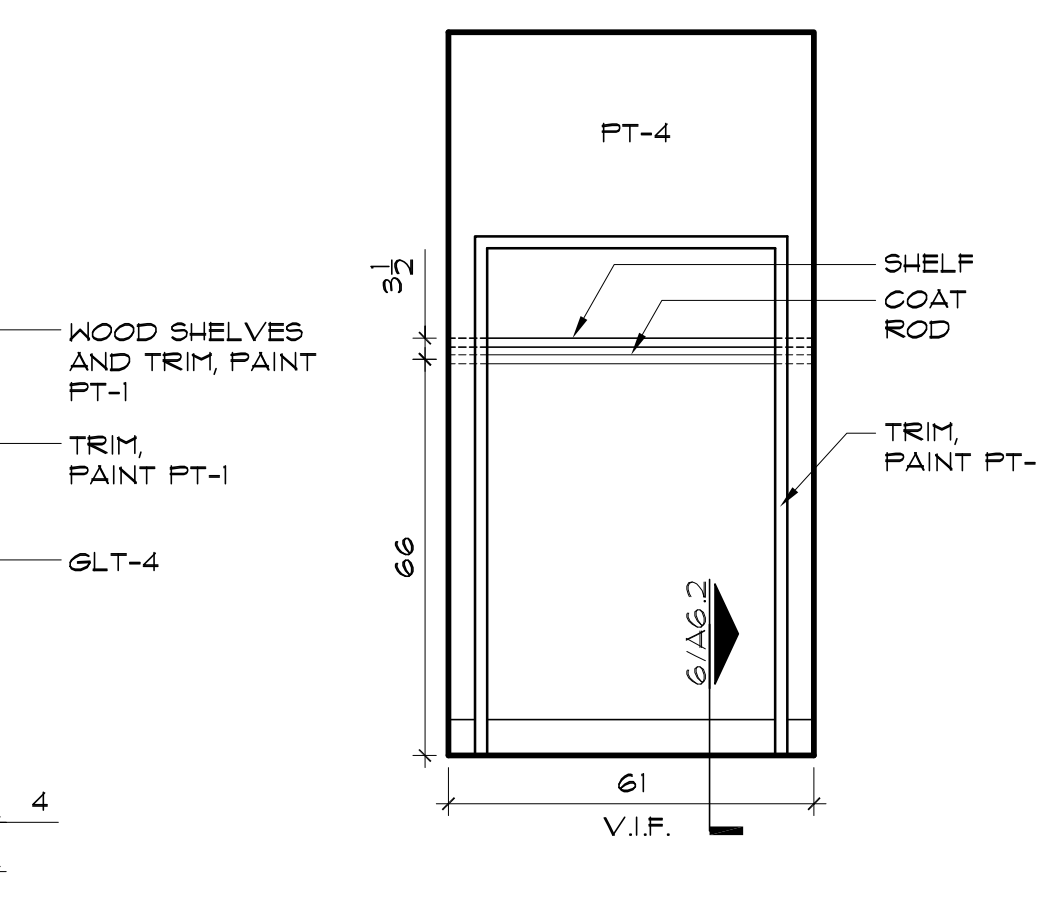
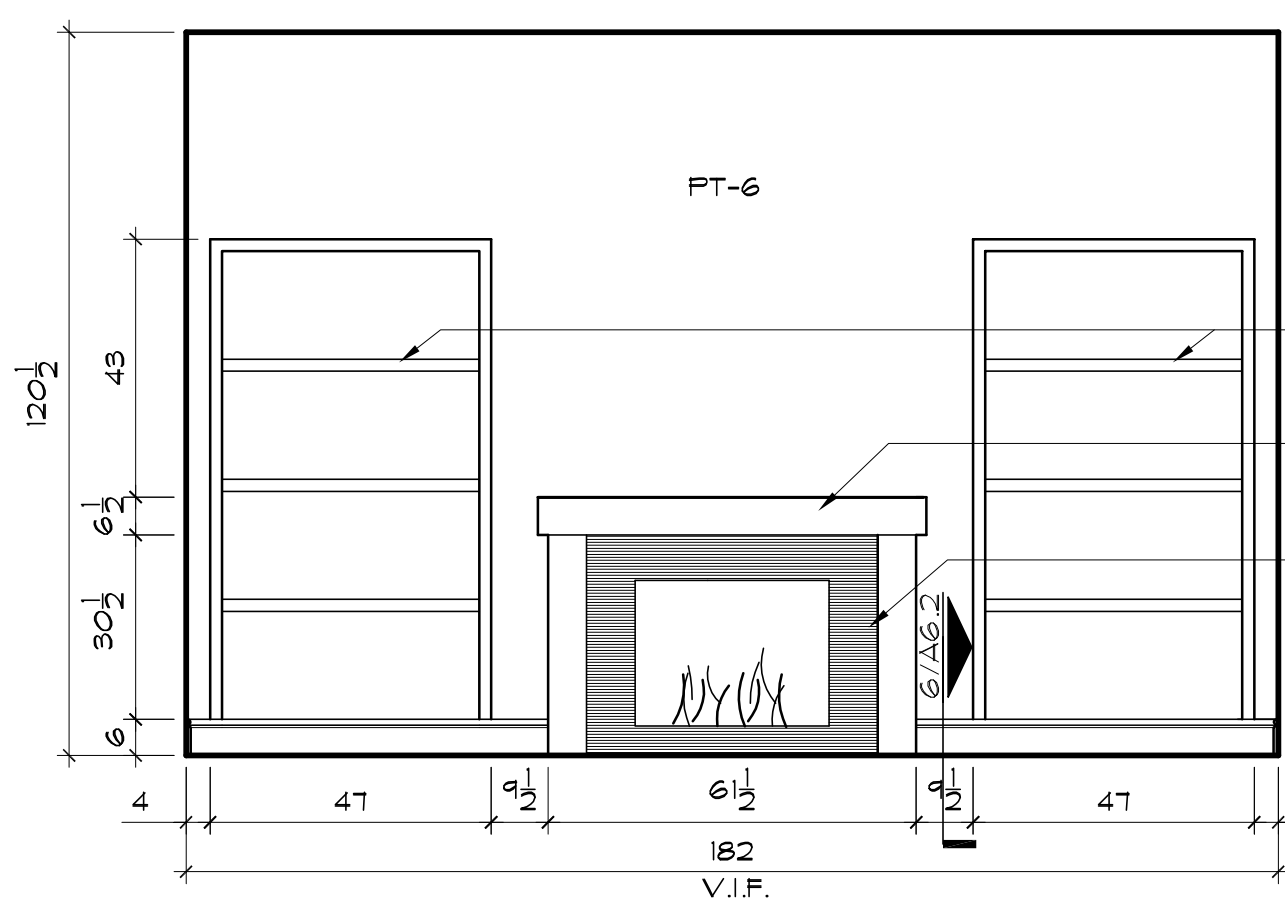

10- CW., M. BEDRM. #210

SCALE: 3/8"=1'-0"

9-CW., CLOSET #209

SCALE: 3/8"=1'-0"

8- WOOD PLATFORM DETAIL 7- WOOD PLATFORM SECT.

SCALE: 6"=1'-0"

6- WOOD BASE DETAIL

SCALE: 6"=1'-0"

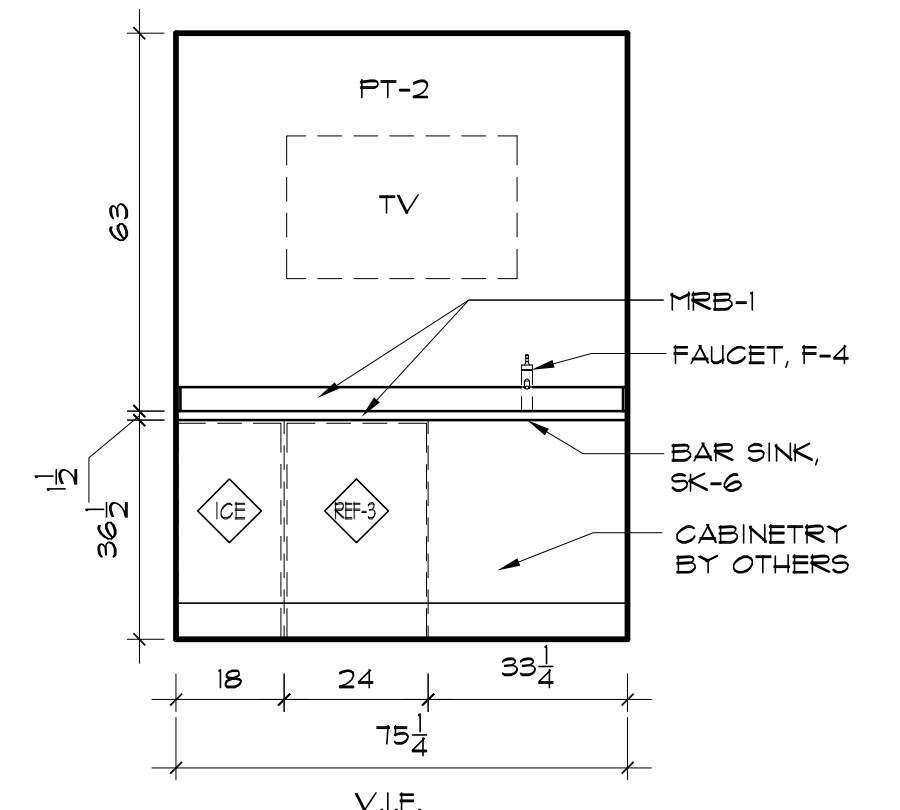
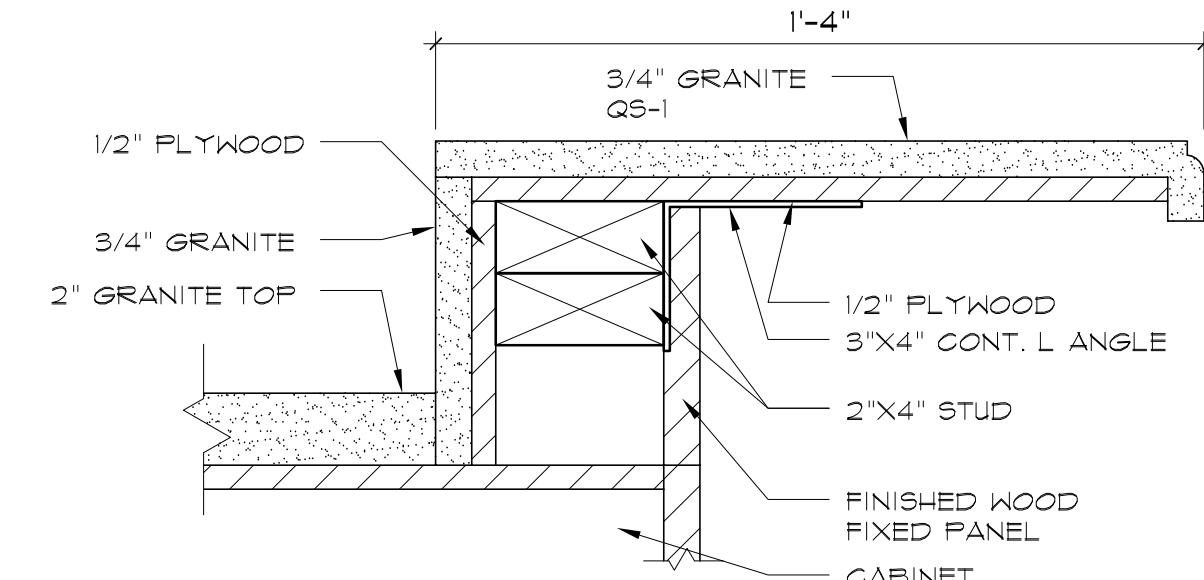
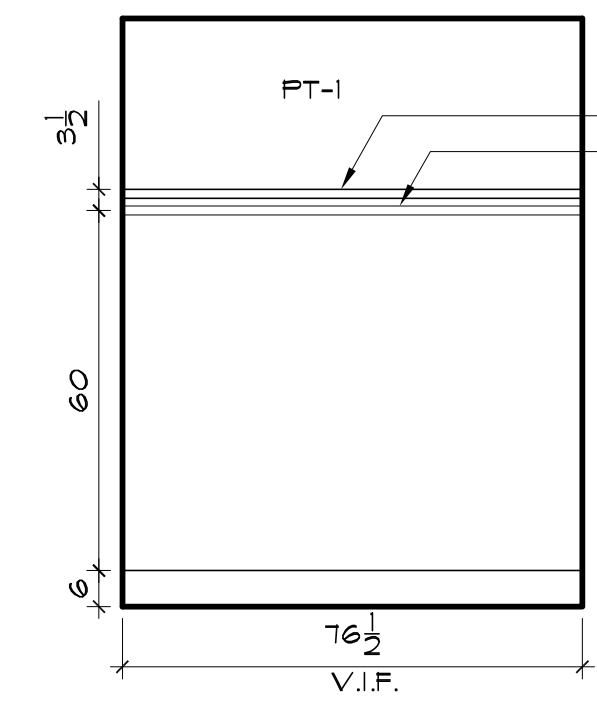
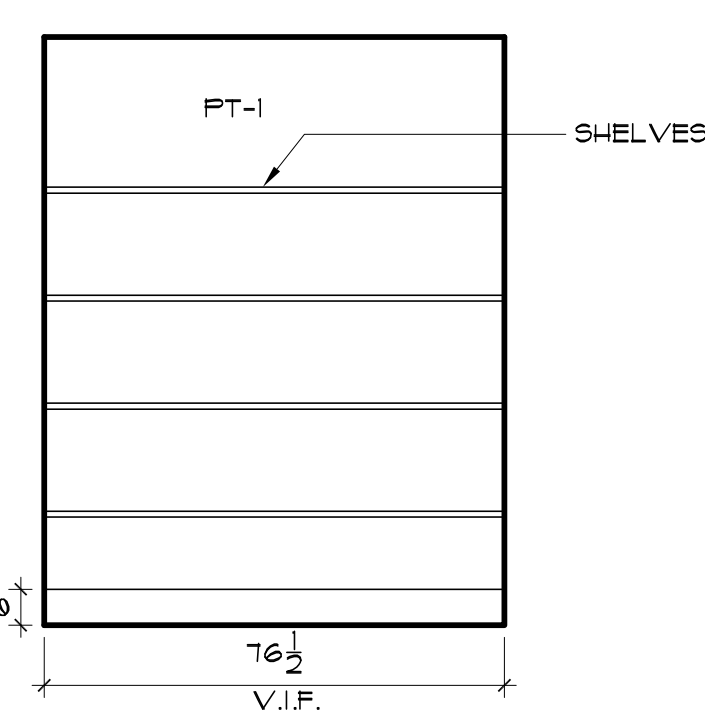
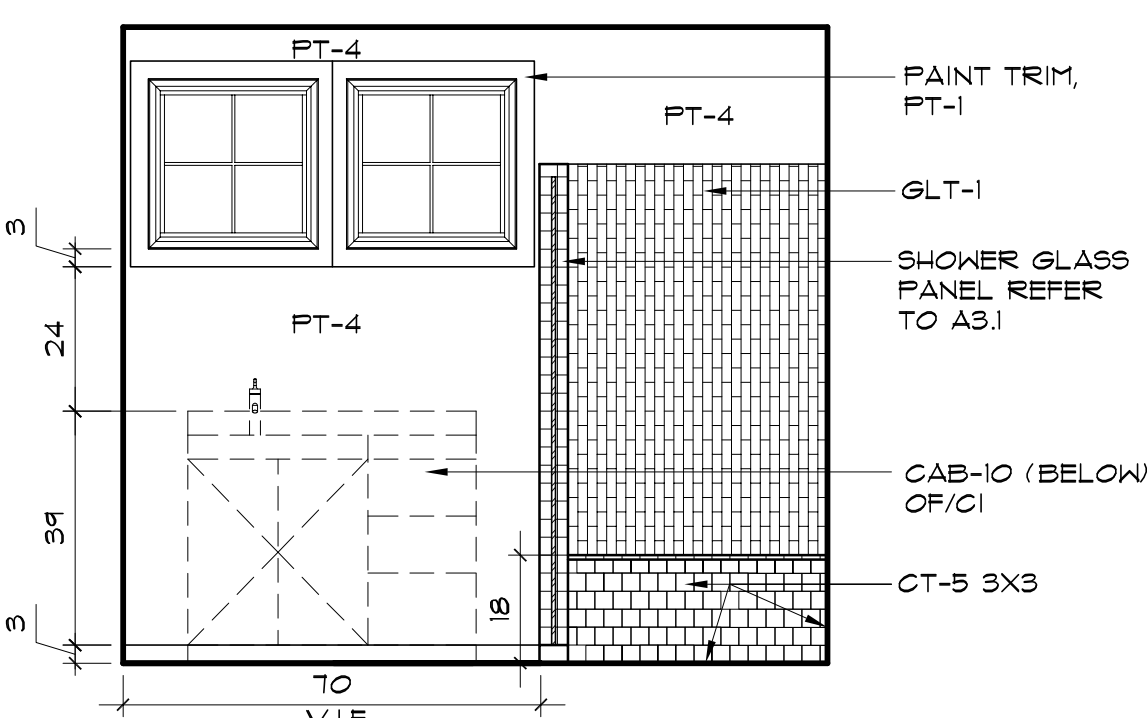

15- RESTROOM #303

SCALE: 3/8"=1'-0"

14-CW., CLOSET #301

SCALE: 3/8"=1'-0"

13-CW., CLOSET #301

SCALE: 3/8"=1'-0"

12- COUNTER EDGE

SCALE: 3"=1'-0"

11-CW., SUN RM. #304

SCALE: 3/8"=1'-0"

THE GRUENE HOUSE
CINNAMON SHORE
175 SEASIDE DR.
PORT ARANSAS, TX 78373

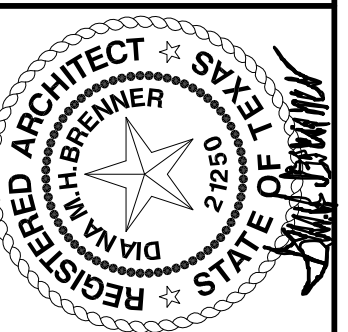

620 N. Delaware
Indianapolis, IN 46204
317.263.1201, tel.
317.263.1200, fax
www.brennerdesign.com

BRENNER DESIGN
Architecture
Construction Management

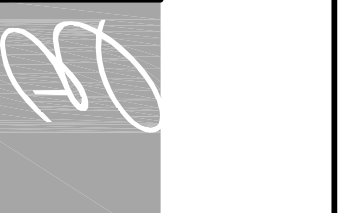

INTERIOR ELEVATIONS & CASEWORK

1 JUN 13 CIN3401R

SHEET NO.

A6.2